



Rulebook

Revised January 2024

Tri-Valley Riders, Inc.

E.T. I. Corral #43

Tri-Valley Riders, Inc. was incorporated in 1976 and is dedicated to equestrian sportsmanship and safety. We are a family oriented club with emphasis on supporting the novice rider and helping young riders grow in the sport. All riders, young, old, skilled and unskilled, are welcomed and encouraged to participate to the best of their ability.

This club embraces the rules of good horsemanship, encourages friendly competition and puts safety of the horse and rider as our first priority. We enjoy our horses and sponsor fun events.

We attribute Tri-Valley Riders' long-term success to the time and service of each and every member. Volunteers, all dedicated to the principles of good equestrian sportsmanship, manage the club.

TABLE OF CONTENTS

Introduction.....	1
Table of Contents.....	2
Governing Rules and Regulations.....	3
General Rules.....	3
Qualifying.....	4
Divisions.....	4
Division of Competition.....	5
Equipment and Attire.....	5
Tack.....	6
Tack Restrictions.....	6
Breakage of Equipment.....	7
Penalties and Disqualifications.....	7
Miscellaneous.....	8
Year End Award Requirements.....	10
Mavericks.....	12
Lyn Morris Award.....	12
Trail Riders Guidelines.....	13
Parade Guidelines.....	14
Gymkhana Events Key.....	15
Rating Table.....	21

Tri-Valley Riders, Inc. - E.T. I. Corral #43

Governing Rules and Regulations

It is the responsibility of all members of Tri-Valley Riders, Inc. (TVR) to be knowledgeable of all Corral rules; any questions regarding Corral policy should be directed towards the Board of Directors of TVR. The Officers and Board together comprise the Board of Directors.

TVR sponsors a Riverside County Gymkhana Association – R.C.G.A. – affiliated gymkhana circuit. Members and non-members may ride to accumulate points toward high point of the day in specified divisions.

General Rules:

1. Whenever the masculine is used, it also includes the feminine.
2. Participants will qualify for division at the first show of the year in which that exhibitor participates.
3. Gymkhana distribution of points in major award categories: A, A 10 & under, AA, AAA, and AAAA.
4. A Junior is considered as one who has not yet reached his eighteenth (18) birthday.
5. No stallion may be ridden by a Junior.
6. Horses that are prone to kick must be “Red Tagged.”
7. Injury - Any two board members of TVR may certify as to the inability of any horse to continue in competition at any given show.
8. Re-rides are allowed for correction or schooling to demonstrate control of your horse and knowledge of the correct event pattern for improved horsemanship. They are not rated for points. Re-rides are allowed for a fee.
9. The use of a horse by multiple riders in the same event will only be allowed if it is not overworking or harmful to the horse; as determined by the Board of Directors at the time of the show. The intent is for occasional events, not a full show. If it is for a full show, then the use of a horse by multiple riders will only be allowed in a walk/trot gait.
10. Items donated for the silent auctions and fundraisers must be new.
11. Upon request the club will give receipts for donations to a fundraising event to the donor directly.
12. Sponsors will be accepted within 30 days of Horse Designation or at our April show.

13. A returned check will be subject to California law. Exhibitor will be prohibited from participation in TVR functions until the account is cleared by cash or money order. Exhibitor is responsible for any fees incurred with a returned check.
14. If proper entry has been made, a rider may substitute one horse for another by notifying the judge prior to the event.
15. Major concerns or issues need to be registered with a board member immediately upon occurrence. Said board member must notify the majority of the board at the time of said occurrence. The Board of Directors will address the issue in a timely manner.

Qualifying:

1. The purpose of qualifying is to determine which division a rider/horse combination will be placed in; the division a rider qualifies in is valid for 12 calendar months from the last TVR show they competed in. Riders must complete a total of 4 events in the day to qualify, consisting of two (2) skill and two (2) speed events.
2. If a rider makes a horse change for a Vet-out, the rider/horse combination must requalify, and year-end points still accrue.
 - a. A rider that only wants to participate in TO or LL does not need to qualify.
 - b. A rider that is 10 or under at the first show, will be placed in the 10U division unless their qualifying times place them in a 2A-4A division.
3. When qualifying, any points earned during the first show will be counted towards year-end if the rider designates their year-end horse that same show.
 - a. Therefore, it is **critical** that riders designate their horse and pay for membership so they can accrue points early.
4. The times which place riders in a specific division are shown below and contained in the TVR Rulebook which is available in the files section of the TVR Facebook page.

If a rider has competed at TVR prior, they may use the qualifying time/division from their previous participation providing that the rider qualified at a TVR show, on the same horse, within the previous 12 calendar months.

For example, if a rider qualified in Division 1A on a horse named Happy in March 2020, they then attend a TVR show in February 2021 using Happy, they can use the 1A qualifying ride from the 2020 show for the 2021 show and it will reset their 12-month calendar.

Divisions:

Lead Line:

The Lead Line division is for new or beginner riders that need a parent, guardian, trainer, 16 & up etc. to help the rider by using a lead line to walk the horse and rider through the patterns. Lead Line riders only ride the first three (3) events at each show. The pattern is typically shortened to 1/3 or 1/2 the size of the normal pattern sizes.

1A 10 & Under:

The 10U division is equivalent to a youth division of the 1A division. Riders who begin the show season at the age of 10 shall compete in the 10U division for the entire year unless their times place them in a division such as 2A-4A.

1A – 4A:

The 1A – 4A divisions have set minimum and maximum times for each pattern; any rider older than 10 cannot be placed any lower than the 1A division. Each division above 1A requires a rider/horse to perform at a higher level with 4A being the fastest division.

Riders who qualify in a division are not restricted to that division for the season. For example, a rider who qualifies in the 1A division at a February show and then runs pattern times at the March show in the 2A division will compete in the 2A division at the next show.

Rider/Horse Examples:

A new rider that has never participated with TVR. Rider Jane, who is 14, attends her first TVR show in February using her horse “Happy”. Jane pays for membership and designates her horse Happy at the first show just in case she decides to compete for year-end.

Example 1: Jane is considered a qualifier, after running the six (6) different patterns, Jane’s times place her in the 1A division, but her performance was fast and consistent enough for her to place 2nd overall at the show. Jane will receive a qualifying ribbon, Show Reserve award, and earn points towards year-end.

Example 2: Jane is considered a qualifier, after running the six (6) different patterns, Jane’s times place her in the 1A division, but her performance did not place her in the top 6 at the show. Jane will receive a qualifying ribbon and earn points towards year-end.

Division of Competition:

1. All competition will be decided and the classifications divided according to speed providing the entry form so states.
2. Exception: Children age of 10 and under may be allowed to run in an age division, provided their speed index is 1A. If their speed index is higher than 1A, they must ride in the speed division qualified.

Equipment and Attire:

1. All gymkhana contestants shall be fully prepared with proper equipment in good condition, ready to compete. Breakage of equipment shall not entitle the rider to re-run in any event.
2. All bits must have a curb strap or curb chain, except for a gag or ring snaffle.
3. Personal equipment may be either English or Western depending on the saddle and tack being used.

4. Only Western, English hats or safety helmets may be worn in the arena during competition. NO baseball hats or visors are allowed. Use of safety helmets is encouraged. All riders must wear a helmet unless over age 18.
5. Riders should be neat, clean and tidy.
 - a. Riders must wear a belt, western shirt or red Tri-Valley shirt and western boots.
 - b. Riders using a stock saddle must wear a belt, western shirt and western boots.
 - c. Hats, chaps, scarves, and spurs are optional.
 - d. Spurs may be of any type, but without sharp points and rowels, and shall not be wired.
 - e. All long sleeves must be rolled down and fastened.
 - f. All shirts must be tucked in and/or buttoned to one button below the collar/top.
 - g. All jackets/outwear must be worn open (unbuttoned or unzipped) during competition.
 - h. No headphones or earbuds allowed while in the arena.
6. Time Only Riders and Non Member Riders must follow the dress code outlined above. Failure to comply and you will not ride, No Refunds.

Tack:

1. Western – standard western type saddles shall be used, it may have a slick or swelled fork, with or without horn, and either high or low cantle.
2. Use of any standard type of bit or hackamore is the choice of the rider, however, the judge may prohibit the use of bits or equipment he may consider severe.
3. English – snaffles, with or without dropped nosebands, Pelhams and full bridles are acceptable.
4. McClellan – or similar saddles shall be considered Western or English depending on the type of bridle used. Appropriate Cavalry Uniform Required.
5. Running or standing martingales are permitted.

Tack Restrictions:

The following items of tack are prohibited in this corral regardless of the age of the rider.

1. Trick riding saddles, jockey saddles.
2. Any bridle or tack not appropriate to the type of saddle or personal attire of the rider.
3. Stinger whips or romels. Crops with less than 1” wide strap on the end, Over and Under with a knot on the end.
4. Any construction or arrangement if considered to be inhumane or dangerous by the judge.
5. Draw reins.

Breakage of Equipment:

1. If tack or equipment should break, or the horse should cast a shoe while negotiating the course, and the difficulty prevents completion of the course, the entry shall be disqualified. Should the entry be able to continue without cruelty to the horse, he may do so without penalty.

Penalties and Disqualifications:

Penalties:

1. A two (2) second penalty shall be assessed for each obstacle knocked down, but the competitor must remain on course as if the obstacle were still standing.

Disqualifications: Any one of the following infractions shall disqualify a horse and rider:

1. At the judge's discretion, failure to enter the arena one minute after the call.
2. Loss of course, includes negotiating obstacles in other than the specified order or direction.
3. Fall of horse and/or rider WHILE ON COURSE.
4. Disqualification of the rider will be imposed if the rider enters the arena to compete and is improperly attired. It is the rider's responsibility to have his horse and himself properly attired for the show.
5. Spurring, striking or beating the horse in any manner forward of the cinch AFTER entering the arena. Touching the horse shall not be considered striking.
6. Any kind of cruelty to the horse, whether or not specifically mentioned in the rule, such as: excessive use of spurs, whip, etc. while on the grounds at any TVR event.
7. Riders will be disqualified and barred from further participation for riding while under the influence of alcohol or drugs.
8. Using foul and/or abusive language is grounds for immediate disqualification for the day. Rule applies to both riders and spectators. Spectators shall be banned from the show grounds.
9. Judges' decisions are final. However, any member or exhibitor wishing to file a protest must do so immediately following the decision. Person must file a protest with the show secretary or Board Member and deposit \$25.00 cash, which shall be forfeited if the protest is not sustained.
10. Protest committee, consisting of two officers or board members not involved in the dispute, shall adjudicate protest. All persons directly concerned shall be notified and given an opportunity to appear. The protest committee shall then adjudicate the issues

impartially, make effective its decision upon the parties in interest and report its determination to the parties in interest. A report of its decision shall also be given to the board of directors of TVR. No person shall enter the arena to contest or inspect the setting of courses until complying with the foregoing ruling. It is the responsibility of the protestor to prove their case. A decision will be made by the end of the show.

11. Any contestant who issues a bad check to TVR shall forfeit all points, if not rectified by the following show.

Miscellaneous:

1. No person shall enter the arena to contest or inspect the setting of courses until after lodging an official protest and depositing a fee of \$25.00 cash.
2. Any entry wishing to dismount in the arena must obtain the permission of the judge to do so.
3. A fall of horse and/or rider while NOT on course shall be considered for a possible remount. Rider may remount with the judge's permission, if no injury to rider and/or horse has taken place.
4. Rider MUST acknowledge the judge prior to starting an event and upon completion of the event or no time will be given. Riders must wait to begin until the judge calls out "Ride when Ready".
5. Riders may be assisted through the gate (16 & up, exit immediately) with the approval of the judge, however, there may not be more than one horse in the arena at the same time (except Leadline).
6. The horse must be under control prior to beginning the course. Under control depends upon the rider's ability, and is thus left to the judge's discretion. The horse must come to a halt and be under control after finishing the course, before leaving the arena, but may take one circle before coming to a halt
7. After your ride, stop straight or circle to the right. Do not circle to the left towards the gate. You must show control of stopping your horse, acknowledge and wait for the judge to respond before leaving the arena.
8. In all events, there must be at least fifteen (15) feet between any barrel or pole to be negotiated and the fence.
9. Gates may only be operated by adults. All gates to the arena shall be kept closed during the running of any event. No one under 18 may be in the arena during a run. No gate shall be opened until the rider has complete control of the horse after finishing the course. Only one gate is allowed open at a time (if using two gates).
10. If a rider falls off or loses control of a horse, DO NOT OPEN ANY GATES. Minors are not allowed in the arena, parents/guardians can crawl through the gate to help the rider and secure the horse. If a rider needs assistance, tell the rider to remain in place or on the ground if they fell off.

11. Only Riders who are up next are allowed in the entry box. This is not a spectator area.
12. Do not crowd the entry box/exit area with horses and people.
13. Lead Line class:
 - a. Gates may be open during Lead Line class.
 - b. Two (2) horse/riders may be in the arena at the same time.
 - c. The age of the horse/rider handler must be 16 or older.
14. Loss of forward motion:
 - a. Horse and rider will not be penalized for Loss of Forward Motions. The increased amount of time it takes to complete the gymkhana course is the only penalty that he or she may incur.
15. Loss of course:
 - a. If horse and rider goes off course there will be no disqualification or penalty, so long as horse and rider corrects the course, and completes the prescribed pattern. Loss of course times will not be rated, so the horse and rider are not bumped down in division due to Loss of course.

January 2024

The Board of Directors has approved these TVR rules. However, there may be additional rulings as needed continuing through the year. All TVR members are invited to attend board meetings.

January 2016

The Board of Directors has approved these TVR rules. However, there may be additional rulings as needed continuing through the year. All TVR members are invited to attend board meetings.

Year End Award Requirements

1. TVR members only, may accumulate points towards year end awards. These points will be tabulated beginning from the date of horse and rider designation. NO POINTS ARE RETROACTIVE.
2. Any contestant riding for year end awards must ride in a minimum of 6 shows for the calendar year.
3. **Sponsorship:**
 - a. Each member wishing to accumulate points in TVR must acquire at least one (1) year-end sponsorship prior to the end of the April show. Those not obtaining a sponsorship will be dropped from points accumulation, NO EXCEPTIONS.
 - b. Sponsorship must be paid in cash, check or card, no in-kind contributions.
 - c. New members will be allowed thirty (30) days from the date of paid membership & Horse designation application to secure a sponsorship and thus retain any points accumulated.
 - d. Sponsorship form must be completed reviewed and signed off by a board member and rider or parent/guardian. Those not fulfilling the sponsorship requirement will be dropped from the points accumulation.
 - e. Sponsors will be accepted anytime they are forthcoming; however, they will not be credited to year end awards requirements except as stated in above year end sponsorship rules.
4. **Hours requirements:**
 - a. Each member wishing to accumulate points towards Year End Awards must work at least twenty (20) hours for the Corral in that calendar year. Leadliners excluded.
 - b. Eight (8) hours must be your own hours (worked by you).
 - c. Twelve (12) hours may be worked by anyone else on behalf of the rider.
 - d. Donations may be used for hours, as follows:
 - i. A maximum of four (4) hours may be received by donating to the fundraiser. One (1) hour with a minimum of a \$25 value or several donations to the fundraiser.
 - ii. The four (4) hours received by giving donations are not part of the eight hours required to be served by the year end rider.
 - iii. The maximum amount of hours per show donation that may be received is one. (You may only donate one item to the snack bar per horse & rider per show, max of 6 shows).
 - e. The donor may not receive hours towards the year-end requirement in addition to a receipt acknowledging the donation.
 - f. All workers must post hours and date worked on the workers sheet at each show, hours must be verified by a Board member. Any hours not verified will be voided.
 - g. Any in show service time must be worked at one (1) hour minimum stand-by increments.
 - h. Board members receive 8 hours to be donated to the horse & rider of their choice.
5. **Designation:**
 - a. Gymkhana riders MUST designate in writing the horse on which they will be accumulating points for the year at the first show ridden in.

- b. Designation forms are available from the show office and gymkhana committee.
 - c. A contestant may ride more than one (1) horse in an event, but will receive points on his/her designated horse only.
 - d. The use of a horse by multiple riders in the same event will only be allowed in a walk/trot gait (with the exception of Lead Line).
7. Injury - In the event a designated horse is injured or unable to continue in year end competition a letter from a veterinarian or decision statement of two (2) Board members as to the inability of the horse to continue in competition for year end awards is mandatory.
8. Injury - A replacement horse may be designated by the rider who will complete the required form. The replacement horse will carry all points earned by the previously designated horse.
9. Once a horse has been substituted for the original designated horse, the original horse may be ridden again during that calendar year a second time for points. If the original horse is unable to compete, then only the substitute horse will be allowed to be substituted again. Any further substitution may be allowed as determined by the Board of Directors.
10. Year-End division placement:
- a. A rider points will be tabulated in the division in which he qualifies. Unless he/she moves out of this division (either up or down) for three (3) consecutive calendar shows.
 - b. If a rider changes division for three (3) consecutive shows, all points for speed visions involved will be re-tabulated. Points for all shows will be moved to the year-end qualifying division.
11. Each rider and horse running for year end awards must sell 5 BBQ Fundraiser tickets for the August dinner.

NOTE:

If you have any questions about these rules contact a Board member. They will be glad to explain any of them to you. Any member not achieving all requirements on this list will be dropped from year end awards. NO EXCEPTIONS.

Mavericks

The Mavericks are the youth group of the club formed to help support the club, sponsor fun and educational events and learn leadership skills in preparation to become the next generation of club officers. The Mavericks include any club member under the age of eighteen. There is an adult advisor. They participate in the gymkhana opening ceremony, organize and manage fun noon time events, and help in the general running of the show. They are key club members in fundraising activities.

Lyn Morris Award

For more than 35 years, Lyn Morris has selflessly dedicated herself to the goals and mission of Tri-Valley Riders (“TVR”) even when she did not have children, grandchildren, friends, or family participating in the club. During her tenure in TVR, Lyn has been a constant, held many positions on the Board and been a staunch advocate to keep the club running and affordable for all participants regardless of abilities, means or background.

Even in times when Lyn’s health impacted her ability to give as much time to the club as she would have liked, she would muster up the energy and make sure she was there to greet the children, parents, and riders at the window with a smile and kind words; she is a constant force that was driven by her love of the equestrian world and the joy on a child’s face when they were excited to compete in their first show, got their first ribbon, or got that first belt buckle.

Children with disabilities, and especially her grandson Deany, have always held an extraordinarily special place in Lyn’s heart. Even when she was not feeling well, she would come down to a show to see these angels participate; everyone could see the joy it brought to her, as her face lit up with a smile, her heart filled with love, and she became excited like a young child.

Lyn’s relationship with Riverside Rancheros helped ensure that someone was always speaking about the importance of keeping TVR and keeping it viable for future generations, so they could have an affordable option to participate in the equestrian world. She understands that we must keep clubs like TVR accessible to all children, whether they have the means or not, and she understood that Rancheros played an important role in the lives of future equestrians.

Lyn’s spirit of giving rubbed off on many in the club, she always was on the lookout for the next officer or volunteer that could keep the club running. She ensured that those leaders held to the traditions of making it a fun, respectful, welcoming environment, and had the best year-end awards in the area.

Trail Riders Guidelines

As with all group activities, success depends on the cooperation, courtesy and good judgment of all participants. For your convenience, we have compiled the following list of commonly accepted trail rules; however, by no means negate the need to use good, sound horse sense in any given situation.

1. Do not get out in front of the trail boss. It is his job to lead the ride.
2. Do not lag behind the drag rider/s. It is his responsibility to see that the ride stays together.
3. Do not run your horse, or even lope up behind or past another horse.
4. Horses that are prone to kick must be "Red Tagged."
5. Keep a safe distance behind the horse in front of you.
6. Smoking only at designated stops.
7. NO LITTER. If you carried it out, carry it back.
8. If you have a question/s don't be afraid to ask.
9. If you have a problem, we're here to help.
10. No dogs allowed.





The members of TVR and your trail boss thank you for your cooperation.

Parade Participants Guidelines

Judging standards are very strict at parades, so we have compiled a list to help everyone make the best possible impression.

1. Horses must be very clean and well groomed. No tangles in mane or tail.
2. Trim bridle path, fetlocks, ears, and all face whiskers including those around the eyes.
3. Scrub hooves and use black hoof dressing on dark hooves and clear hoof dressing/polish on light hooves.
4. Bring some clean brushes, rub rags, water, etc. to the parade with you.
5. Clean and condition all equipment.
6. Polish all silver.
7. Wash and shine bits.
8. Riders must be clean and neat.
9. Wear dark blue jeans and plain cotton/polyester white western shirts.
10. Reins are to be held in the left hand, romel in right.
11. Try to have stirrups low enough so your legs hang almost straight down and sit up straight. This improves overall appearance.
12. Be on time, smile, and have fun!
13. Please contact your parade coordinator prior to riding.

EVENTS KEY

BARREL = () STAKE OR POLE = ()
 BARREL, STAKE OR POLE MAY BE USED = ()
 WHEN THIS SYMBOL () IS USED YOU MUST USE ALL BARRELS OR ALL STAKES OR POLES IN THAT EVENT. STAKES AND POLES ARE THE SAME.

ARIZONA BIG T 21' x 21' x 21' x 40' x 90' (SPEED AND SKILL)

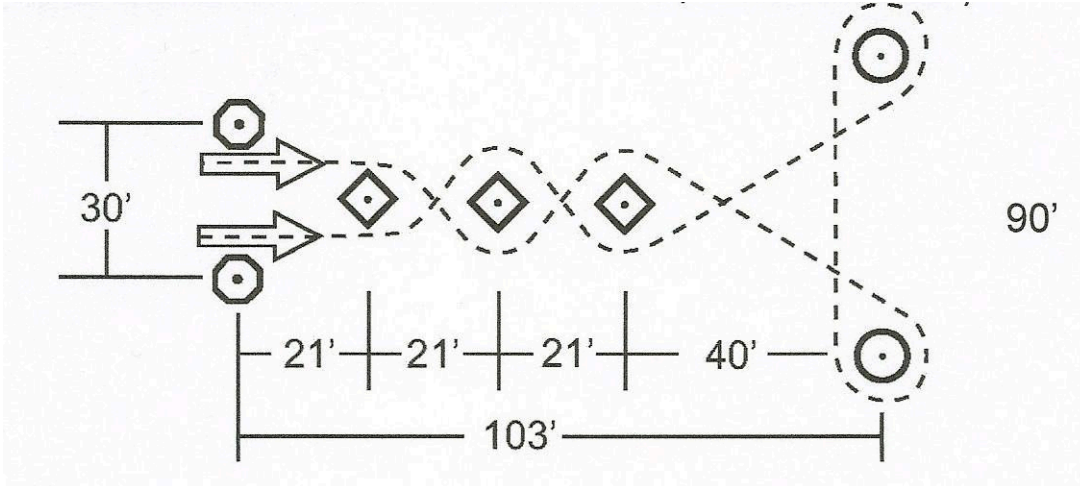

BIG M 30' x 105' x 90' (SPEED)

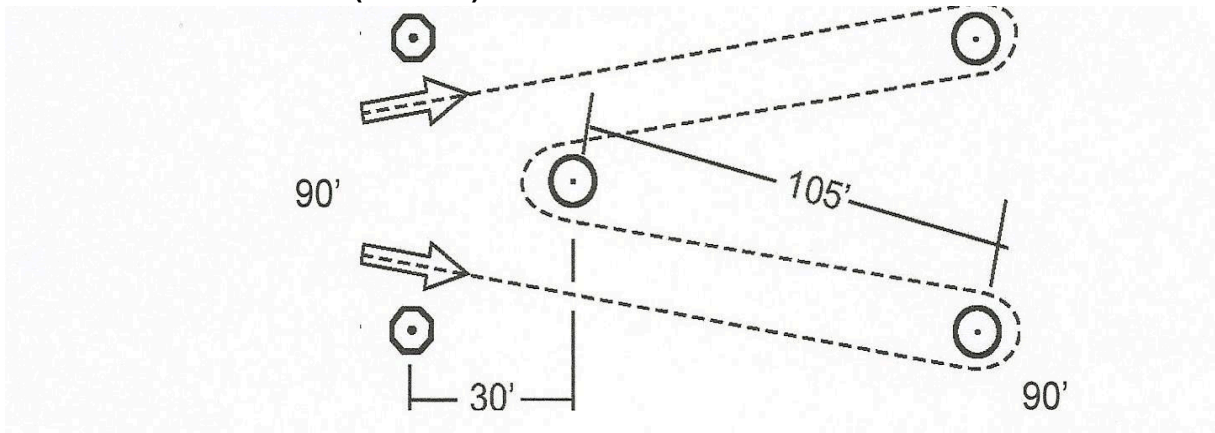

BIRANGLE STAKES OR BOWTIE BARRELS 125' x 75' (SPEED)

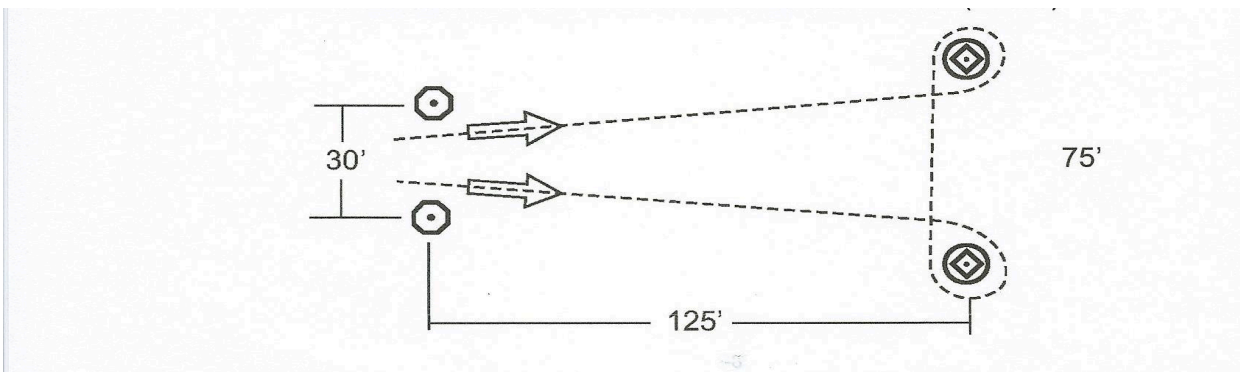
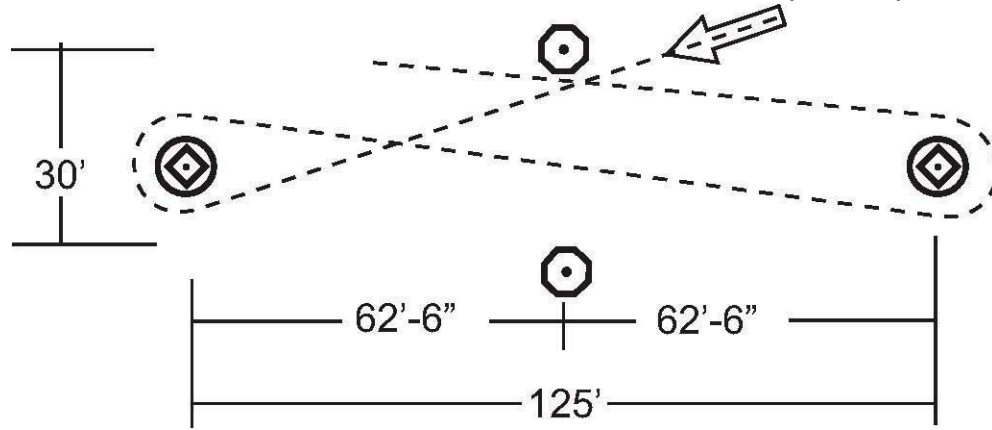
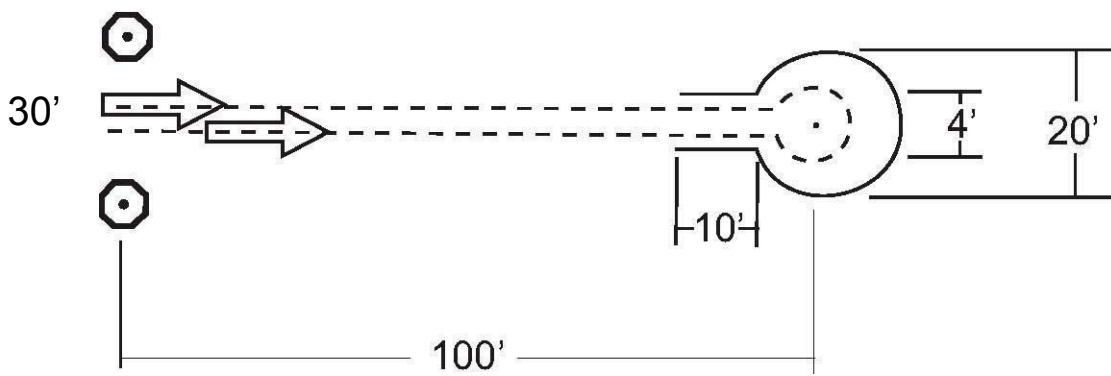

FIGURE - 8 BARRELS OR FIGURE - 8 STAKES 62' 1/2" x 62' 1/2" (SKILL)



KEYHOLE 100' TO CENTER 4' x 10' THROAT, 20' CIRCLE (SKILL)



KEYHOLE BARREL 84' X 6' SQUARE X 10' (SKILL)

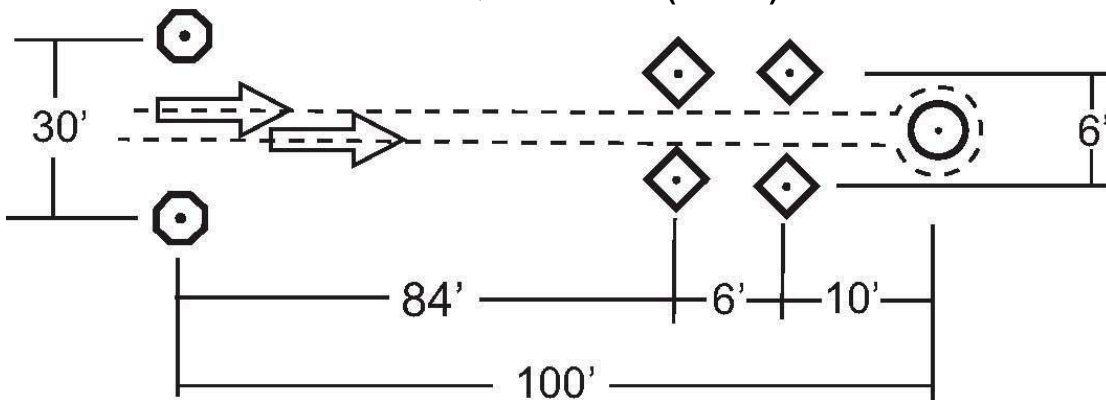

POLES 1- POLE BENDING 20' X 20' X 20' X 20' X 20' (SKILL)

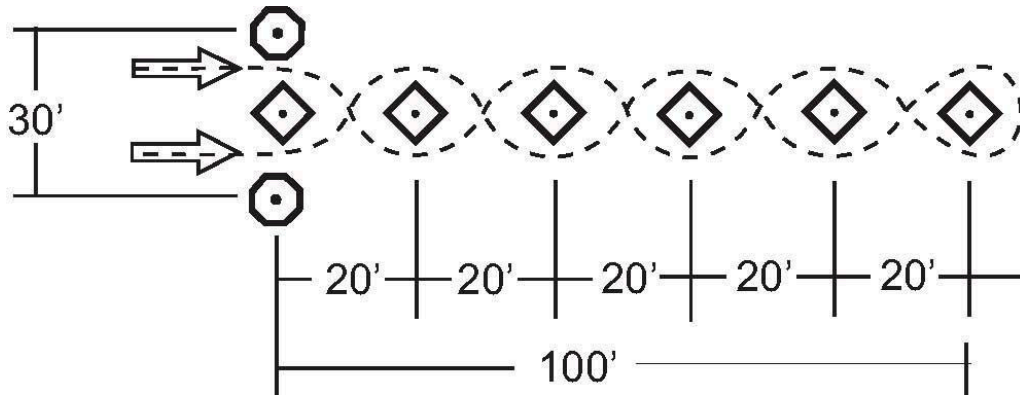

QUADRANGLE STAKES OR QUADRANGEL BARRELS 75' X 75' (SKILL)

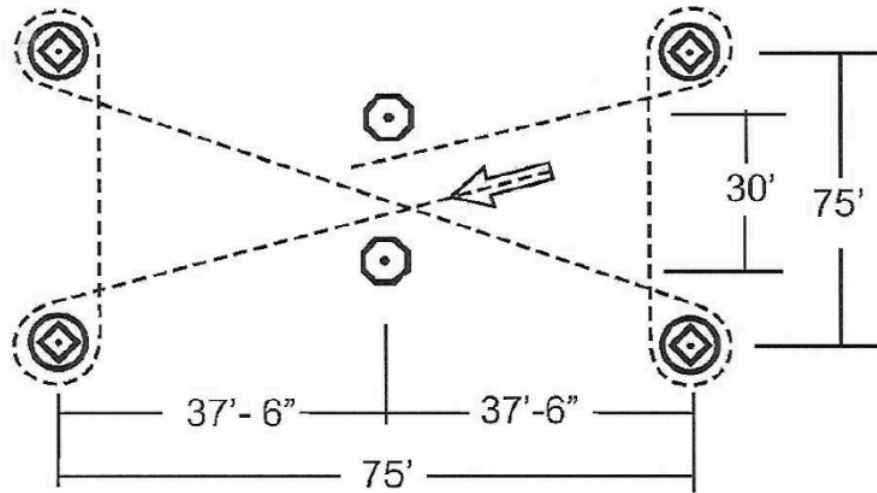

SCRAMBLE BARRELS 30' X 30' X 105' (SPEED AND SKILL)

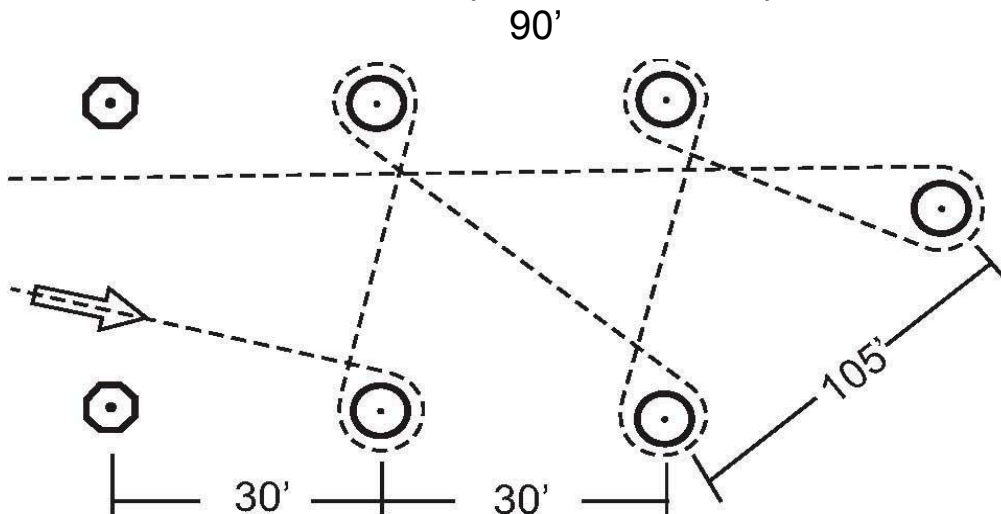

SHOESTRING POLES OR SHOESTRING BARRELS 30' X 30' X 30' X 35' (SKILL)

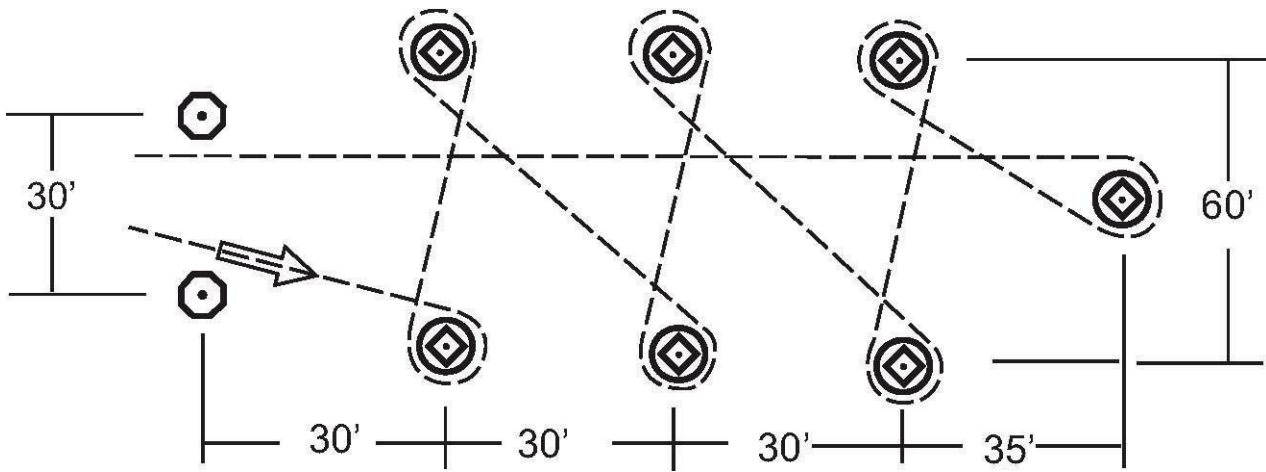

SINGLE POLE OR SINGLE BARREL 150' (SPEED)

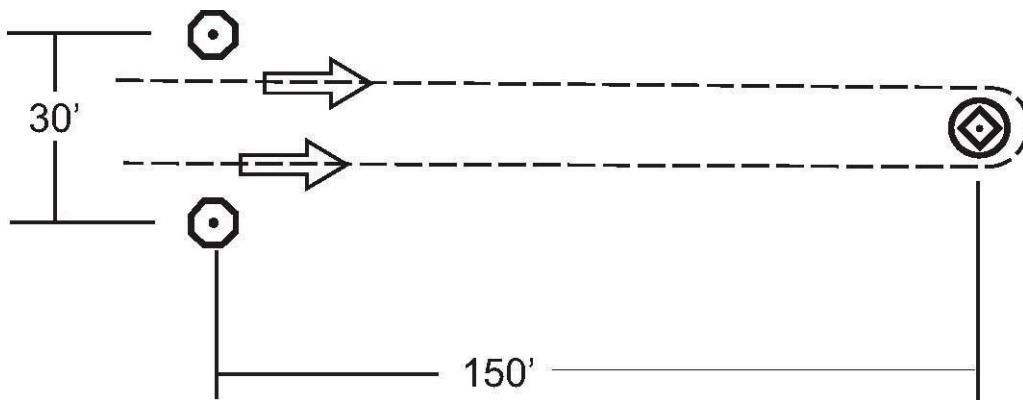

SINGLE FLAG 150' (SKILL) STICK A FLAG IN SAND FILLED BUCKET, THEN PULL THE OTHER FLAG OUT.

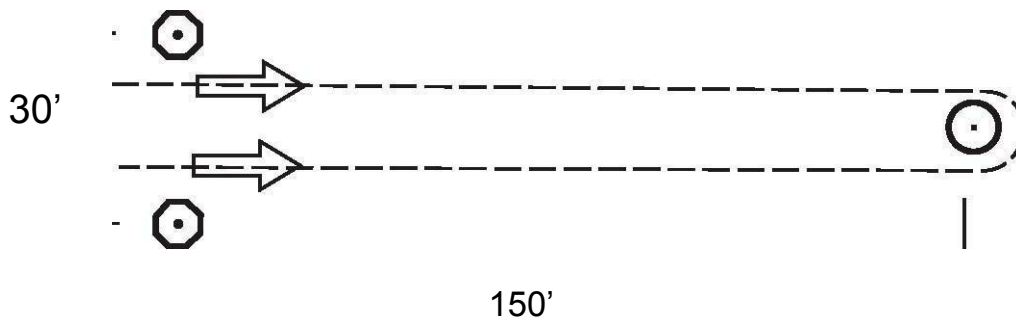

SKILL POLES AND SKILL BARRELS 100' X 75' X 37' X 37' ACROSS (SPEED & SKILL)

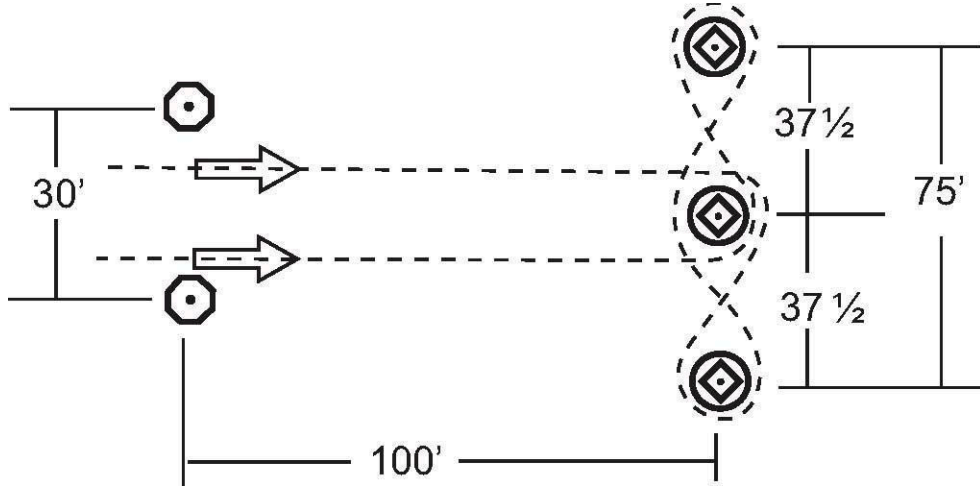

SPEEDBALL 100' DROP GOLF BALL INTO CONE (SKILL)

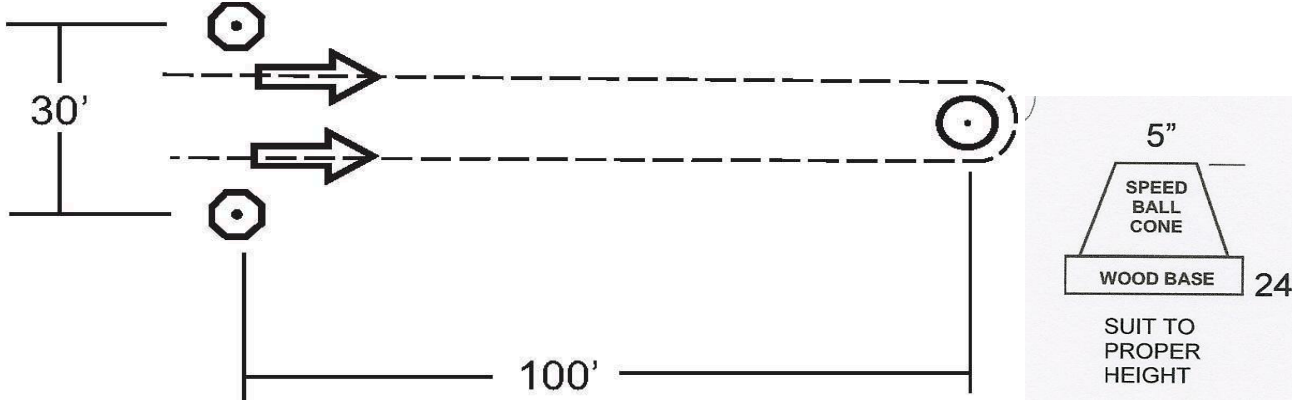

SPEED POLES OR SPEED BARRELS 30' X 60' X 60' (SPEED) '

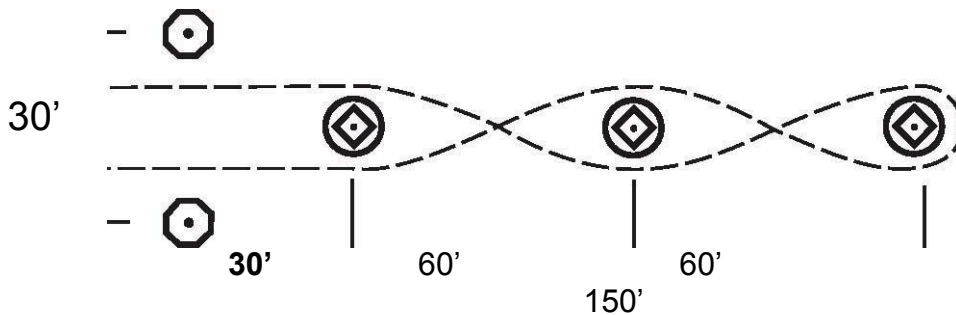

TEXAS BARRELS (STANDARD SIZE PATTERN) 90' X 60' X 105' (SPEED)

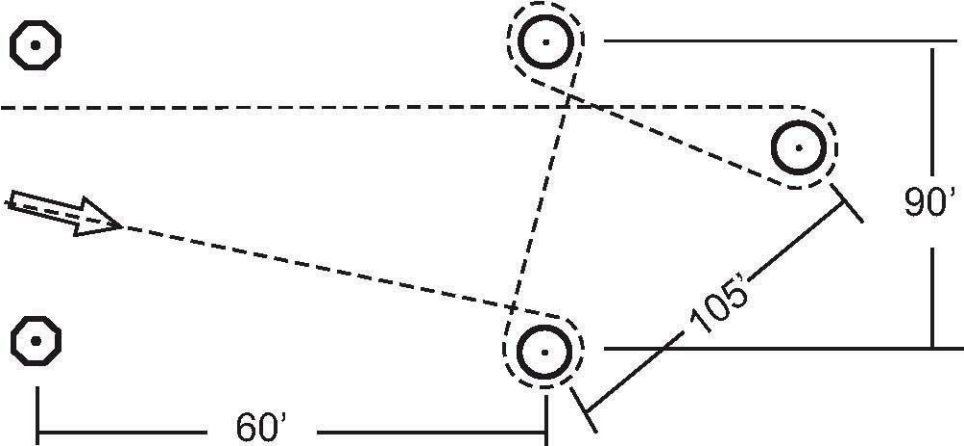

POLES 2 - WASHINGTON POLES 21' X 21' X 21' X 21' X 21' X 21' (SKILL)

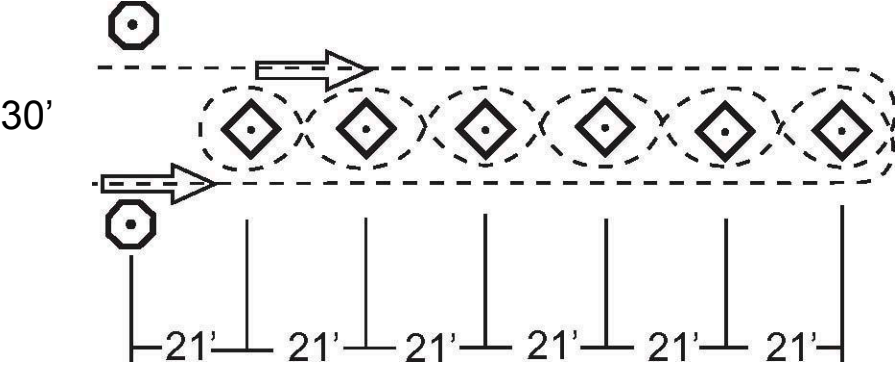

RATING TABLES

Developed for use, in perpetuity for the Riverside County Gymkhana Association
Copyright 1990 'Z Marketing Group All Rights Reserved

DIVISION	AAAA	AAAA	AAA	AAA	AA	AA	A	A
FACTOR	4.50	4.00	3.50	3.00	2.50	2.00	1.50	1.00
ARIZONA BIG-T ARIZ Skill	0.00 17.49	17.50 18.49	18.50 18.99	19.00 19.49	19.50 19.99	20.00 20.99	21.00 21.99	22.00 0.00
BIG-M BIG-M Speed	0.00 19.24	19.25 19.74	19.75 20.24	20.25 20.74	20.75 21.24	21.25 21.74	21.75 22.24	22.25 0.00
BIRANGLE STAKE BI Speed	0.00 14.49	14.50 14.99	15.00 15.24	15.25 15.49	15.50 15.74	15.75 15.99	16.00 16.49	16.50 0.00
BOWTIE BARRELS BOWTIE Speed	0.00 14.49	14.50 14.99	15.00 15.24	15.25 15.49	15.50 15.74	15.75 15.99	16.00 16.49	16.50 0.00
FIGURE-8 BARRELS FIG8B Skill	0.00 11.09	11.10 11.59	11.60 11.99	12.00 12.59	12.60 12.99	13.00 13.59	13.60 13.99	14.00 0.00
FIGURE-8 STAKES FIG8P Skill	0.00 11.09	11.10 11.59	11.60 11.99	12.00 12.59	12.60 12.99	13.00 13.59	13.60 13.99	14.00 0.00
KEYHOLE KEYC Skill	0.00 7.99	8.00 8.49	8.50 8.74	8.75 8.99	9.00 9.49	9.50 9.99	10.00 10.49	10.50 0.00
KEYHOLE BARREL KEYB Skill	0.00 7.99	8.00 8.49	8.50 8.74	8.75 8.99	9.00 9.49	9.50 9.99	10.00 10.49	10.50 0.00
POLE BENDING P1 Skill (POLES 1)	0.00 10.59	10.60 10.99	11.00 11.49	11.50 11.99	12.00 12.49	12.50 12.99	13.00 13.49	13.50 0.00
QUADRANGLE BLS QUADB Skill	0.00 20.49	20.50 20.99	21.00 21.49	21.50 21.99	22.00 22.49	22.50 22.99	23.00 23.99	24.00 0.00
QUADRANGLE STK QUAD Skill	0.00 20.49	20.50 20.99	21.00 21.49	21.50 21.99	22.00 22.49	22.50 22.99	23.00 23.99	24.00 0.00
SCRAMBLE BARREL SCRAMB Combin	0.00 28.99	29.00 29.99	30.00 30.49	30.50 31.49	31.50 31.99	32.00 32.99	33.00 33.49	33.50 0.00
S'STRING POLES SHOE Skill	0.00 33.49	33.50 33.99	34.00 34.99	35.00 35.99	36.00 36.99	37.00 37.99	38.00 38.49	38.50 0.00
S'STRING BARRELS SHOEB Skill	0.00 33.49	33.50 33.99	34.00 34.99	35.00 35.99	36.00 36.99	37.00 37.99	38.00 38.49	38.50 0.00
SINGLE BARREL SINGLEB Skill	0.00 9.89	9.90 10.19	10.20 10.34	10.35 10.49	10.50 10.64	10.65 10.79	10.80 10.99	11.00 0.00
SINGLE FLAG SINGLEF Skill	0.00 10.19	10.20 10.59	10.60 10.74	10.75 11.09	11.10 11.59	11.60 11.99	12.00 12.49	12.50 0.00
SINGLE POLE SINGLEP Skill	0.00 9.89	9.90 10.19	10.20 10.34	10.35 10.49	10.50 10.64	10.65 10.79	10.80 10.99	11.00 0.00
SKILL BARRELS SKILL Combin	0.00 17.49	17.50 18.49	18.50 18.74	18.75 18.99	19.00 19.49	19.50 19.99	20.00 20.49	20.50 0.00
SKILL POLES SKILLP Combin	0.00 17.49	17.50 18.49	18.50 18.74	18.75 18.99	19.00 19.49	19.50 19.99	20.00 20.49	20.50 0.00
SPEED BALL SBALL Skill	0.00 7.99	8.00 8.49	8.50 8.74	8.75 8.99	9.00 9.49	9.50 9.99	10.00 10.49	10.50 0.00
SPEED BARRELS SPEEDB Speed	0.00 10.19	10.20 10.59	10.60 10.74	10.75 11.09	11.10 11.59	11.60 11.99	12.00 12.49	12.50 0.00
SPEED POLES SPEEDP Speed	0.00 10.19	10.20 10.59	10.60 10.74	10.75 11.09	11.10 11.59	11.60 11.99	12.00 12.49	12.50 0.00
TEXAS BARRELS TEXAS Speed	0.00 19.49	19.50 19.99	20.00 20.49	20.50 20.99	21.00 21.49	21.50 21.99	22.00 22.49	22.50 0.00
WSHNGTN POLES WASH Skill (POLES 2)	0.00 21.99	22.00 22.99	23.00 23.49	23.50 23.99	24.00 24.99	25.00 25.99	26.00 26.99	27.00 0.00

DIVISION PARAMETERS

A = 1.00 TO 1.25
AA = 1.26 TO 2.50
AAA = 2.51 TO 3.75
AAAA = 3.76 TO 5.00